

Ficha técnica del producto

Especificaciones



INTERRUPTOR TERMOMAGNETICO QOB 1P. 10 A. ATORNILLABLE 10kA 120/240V

QOB110

Principal

Product	Interruptor automático en miniatura
Range	QOD
Current Rating	10 A
Voltage Rating	120 V CA 120 V CA 48 V DC
Mounting Type	Bolt-on (**)
Number of Poles	1P
Circuit Breaker Type	Standard (**)
Ratings	HACR rated (**)
Electrical Connection	Pressure plate (**)

Opcionales

Interrupt Rating	10 kA 120 V CA 50/60 Hz 10 kA 120 V CA 50/60 Hz 5 kA 48 V DC
Number of Panel Spaces	1
Wire Size	AWG 14...AWG 8 cobre o aluminio
Tightening Torque	5 N.m 10...25 mm ² AWG 8...AWG 2
Height	76 mm
Width	19 mm
Depth	74 mm
Peso del producto	0.132 kg

Ambiente

Certifications	Registrado por UL CSA
Ambient Rating	40 °C

Unidades embalaje

Unit Type of Package 1	PCE
Number of Units in Package 1	1

Package 1 Height	2.54 cm
Package 1 Width	9.144 cm
Package 1 Length	9.144 cm
Package 1 Weight	131.542 g

Oferta sostenibilidad

Estado de oferta sostenible	Producto Green Premium
Reglamento REACH	Declaración de REACH
Directiva RoHS UE	Conforme Declaración RoHS UE
Sin metales pesados tóxicos	Sí
Sin mercurio	Sí
Información sobre exenciones de RoHS	Sí
Normativa de RoHS China	Declaración RoHS China Producto fuera del ámbito de RoHS China. Declaración informativa de sustancias
Presencia de halógenos	Producto libre de halógenos

Garantía contractual

Periodo de garantía	18 months
---------------------	-----------

Ficha técnica del producto

Ilustración técnica

QOB110

Dimensiones

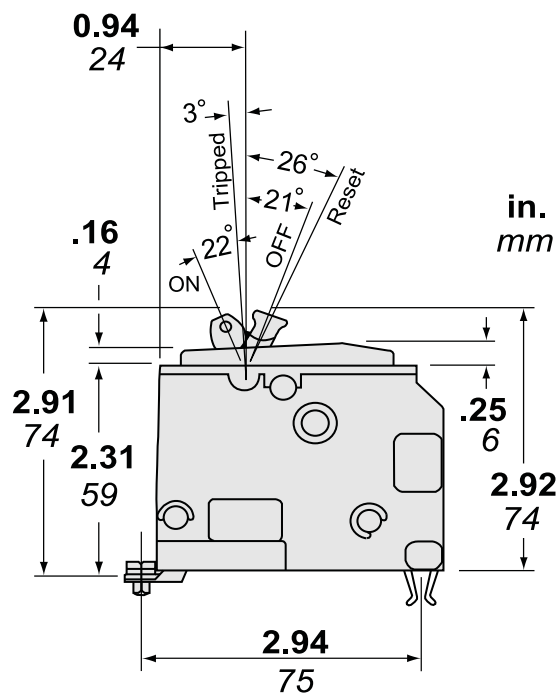
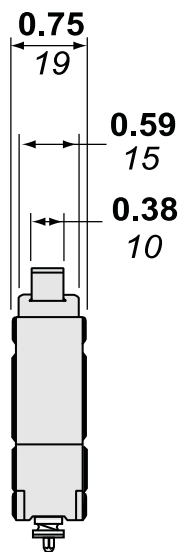
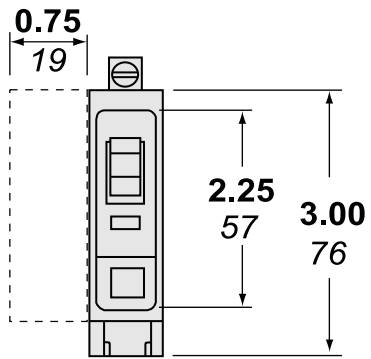

Dimensions are approximate. Refer to technical documentation for additional detail.

Reemplazo(s) recomendado(s)